



GPL 12520

12V 52Ah

GPL 12520 is a general purpose battery up to 10 years expected life under normal float charge. As with all CSB batteries, all are rechargeable, highly efficient, leak proof and maintenance free.



Specification

Cells Per Unit	6
Voltage Per Unit	12
Capacity	52Ah @ 20hr-rate to 1.75V per cell @25 °C (77°F)
Weight	Approx. 18 kg (39.68 lbs)
Maximum Discharge Current	500A(5sec)
Internal Resistance	Approx. 5.9 mΩ
Operating Temperature Range	Discharge: -15°C~50°C (5°F~122°F) Charge: -15 °C~40°C (5°F~104°F) Storage: -15°C~40°C (5°F~104°F)
Nominal Operating Temperature Range	25 °C±3°C(77°F±5°F)
Float Charging Voltage	13.5 to 13.8 VDC/Unit Average at 25 °C (77°F)
Recommended Maximum Charging Current Limit	15.6A
Equalization and Cycle Service	14.4 to 15.0 VDC/unit Average at 25 °C (77°F)
Self Discharge	CSB Batteries can be stored for more than 6 months at 25°C(77°F). Please charge batteries before using. For higher temperatures the time interval will be shorter.
Terminal	B4-L terminal to accept M6 nut & bolt
Container Material	Polypropylene(UL 94-V0/File E50955)*Flammability resistance of (UL 94-HB/File E216959) can be available upon request.



CSB-manufactured batteries are UL-recognized components under UL924 and UL1989. CSB is also certified by ISO 9001 and ISO 14001.

Dimensions

unit:(MM)

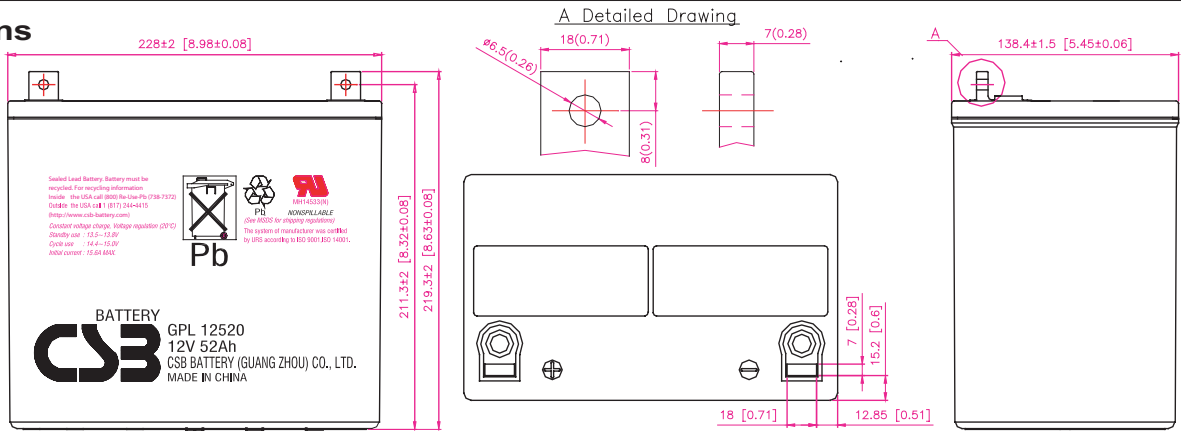

Constant Current Discharge Characteristics Unit:A (25°C ,77°F)

F.V/Time	5MIN	10MIN	15MIN	30MIN	1HR	2HR	3HR	4HR	5HR	8HR	10HR	20HR
1.60V	233	149	112	64.9	36.8	21.0	15.0	11.7	9.90	6.66	5.42	2.91
1.67V	208	139	107	63.1	36.0	20.8	14.8	11.6	9.81	6.60	5.40	2.90
1.70V	197	134	104	62.0	35.7	20.6	14.7	11.5	9.76	6.58	5.37	2.89
1.75V	179	126	101	60.6	35.2	20.3	14.5	11.4	9.69	6.54	5.34	2.88
1.80V	161	118	96.8	59.2	34.7	20.1	14.3	11.3	9.62	6.50	5.31	2.87
1.85V	143	111	93.0	57.8	34.2	19.9	14.2	11.2	9.55	6.46	5.29	2.85

Constant Power Discharge Characteristics Unit:W (25°C ,77°F)

F.V/Time	5MIN	10MIN	15MIN	30MIN	1HR	2HR	3HR	4HR	5HR	8HR	10HR	20HR
1.60V	2,209	1,477	1,125	668	386	221	154	124	106	71.5	58.7	34.4
1.67V	2,012	1,381	1,058	654	380	219	153	123	105	71.4	58.4	34.3
1.70V	1,917	1,335	1,028	646	376	217	152	122	104	71.3	58.2	34.2
1.75V	1,767	1,252	986	632	372	214	151	121	103	70.9	58.0	33.7
1.80V	1,619	1,169	944	615	368	212	150	120	102	70.4	57.9	33.3
1.85V	1,459	1,088	904	598	363	209	149	119	101	69.9	57.7	33.0

- All mentioned values are average values.
- Tolerance: X<6min(+15%~-15%), 6min ≤ X<10min(+12%~-12%), 10min ≤ X<60min(+8%~-8%), X ≥ 60min(+5%~-5%)

Trickle (or Float) Service Life

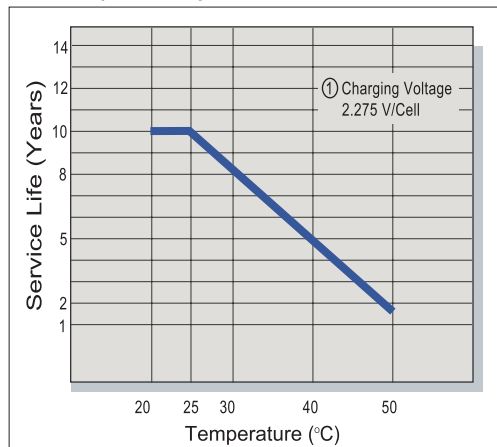

Capacity Retention Characteristic

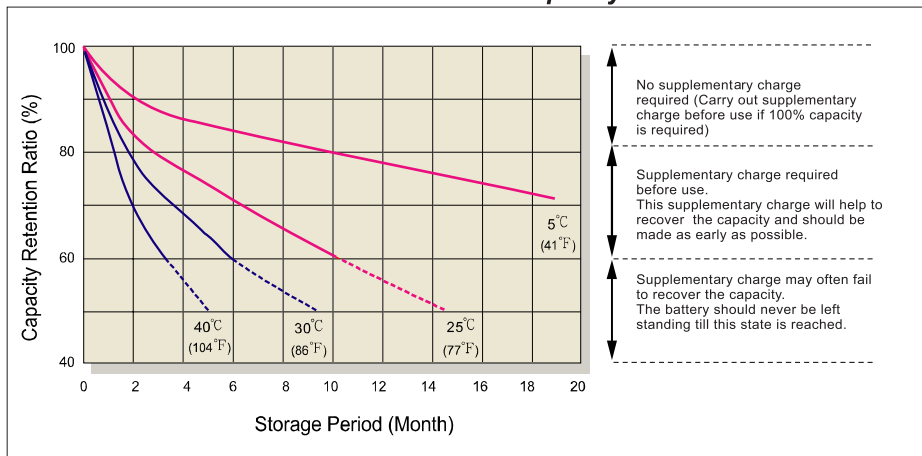

Battery Voltage and Charge Time for Standby Use

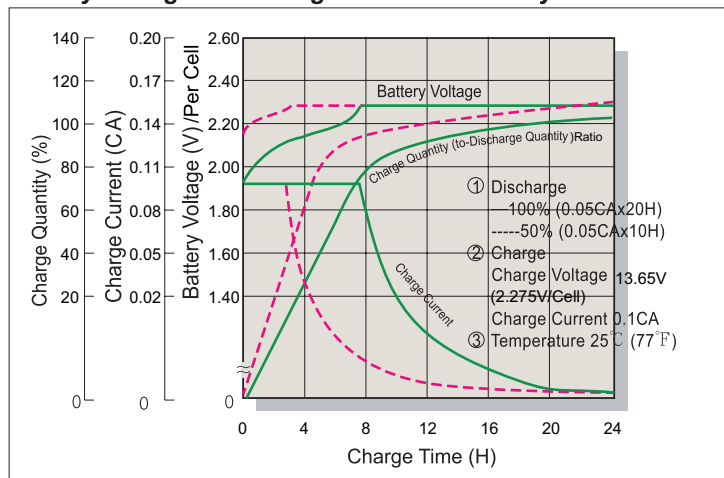

Cycle Service Life

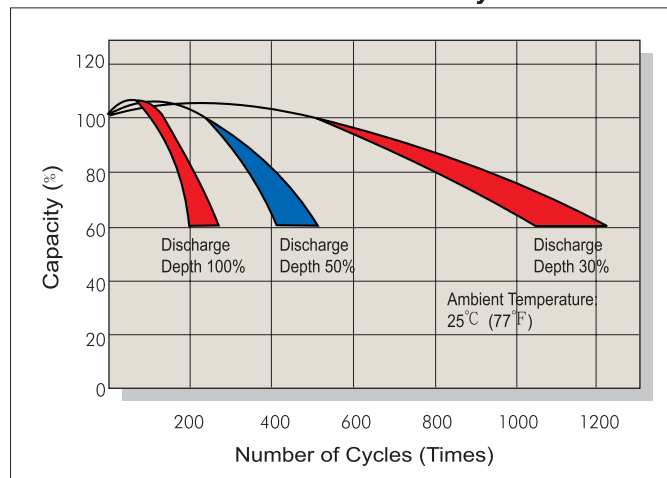

Battery Voltage and Charge Time for Cycle Use

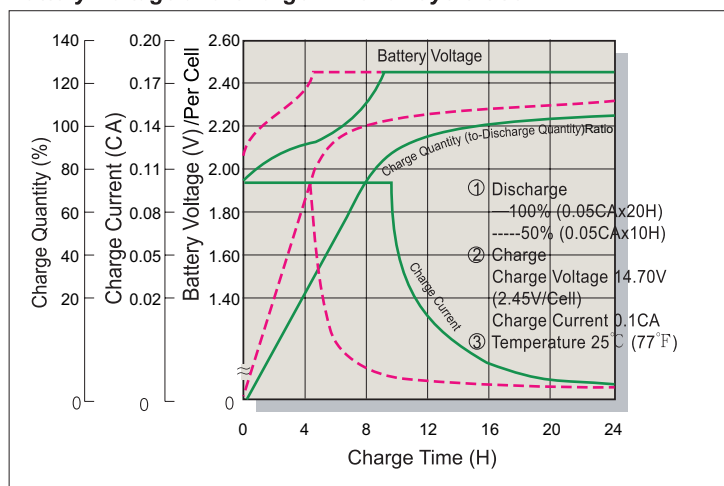

Terminal Voltage (V) and Discharge Time

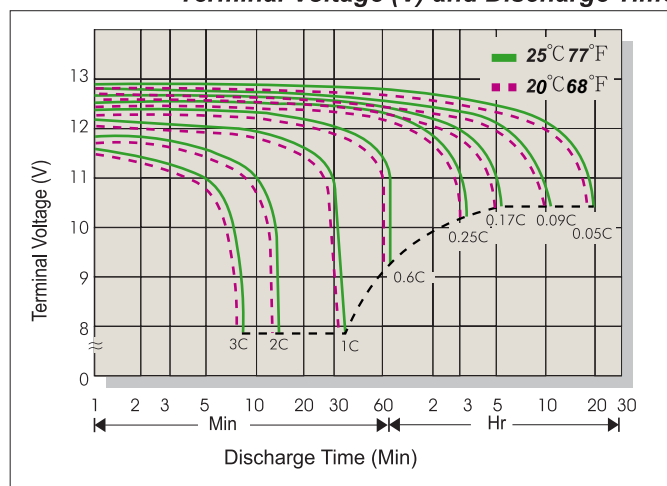

Charging Procedures

Application	Charge Voltage(V/Cell)			Max.Charge Current
	Temperature	Set Point	Allowable Range	
Cycle Use	25°C (77°F)	2.45	2.40~2.50	0.3C
Standby	25°C (77°F)	2.275	2.25~2.30	

Discharge Current VS. Discharge Voltage

Final Discharge Voltage V/Cell	1.75	1.70	1.60	1.30
Discharge Current(A)	0.2C>(A)	0.2C<(A)<0.5C	0.5C<(A)<1.0C	(A)>1.0C

Sales Office URL: WWW.CSB-BATTERY.COM

CSB BATTERY CO., LTD.
TAIWAN OFFICE
Tel: +886-2-2555-5600
Fax: +886-2-2555-3300
E-mail: service@csb-battery.com.tw

CSB BATTERY TECHNOLOGIES (BEIJING) CO., LTD.
BEIJING OFFICE
Tel: +86-10-59621300/59621301/59621302/59621303
Fax: +86-10-59621304
mail: chinasls@csb-battery.com

CSB BATTERY TECHNOLOGIES, INC
USA OFFICE
Tel: +1-817-244-7777/1-8003 CSBUSA(272872)
Fax: +1-817-244-4445
E-mail: csb@csb-battery.com

CSB BATTERY LOGISTICS (SHANGHAI) CO., LTD.
SHANGHAI OFFICE
Tel: +86-21-5046-1622, 5046-0833
Fax: +86-21-5064-3314
E-mail: chinasls@csb-battery.com

CSB BATTERY OF NETHERLANDS B.V
NETHERLANDS OFFICE
Tel: +31(0) 180 418 140
Fax: +31(0) 180 418 327
E-mail: eurosales@csb-battery.com

CSB BATTERY LOGISTIC (SHANGHAI) CO., LTD.
SHENZHEN OFFICE
Tel: +86-755-8831-6488/6396/16356
Fax: +86-755-8831-6548
mail: she@csb-battery.com.cn